

REVISIONS

REV	DESCRIPTION	DATE (YR-MO-DA)	APPROVED
1	EFFECTIVE FROM SERIAL NUMBER 21083 AND FORWARD	97-09-23	L.H.F.

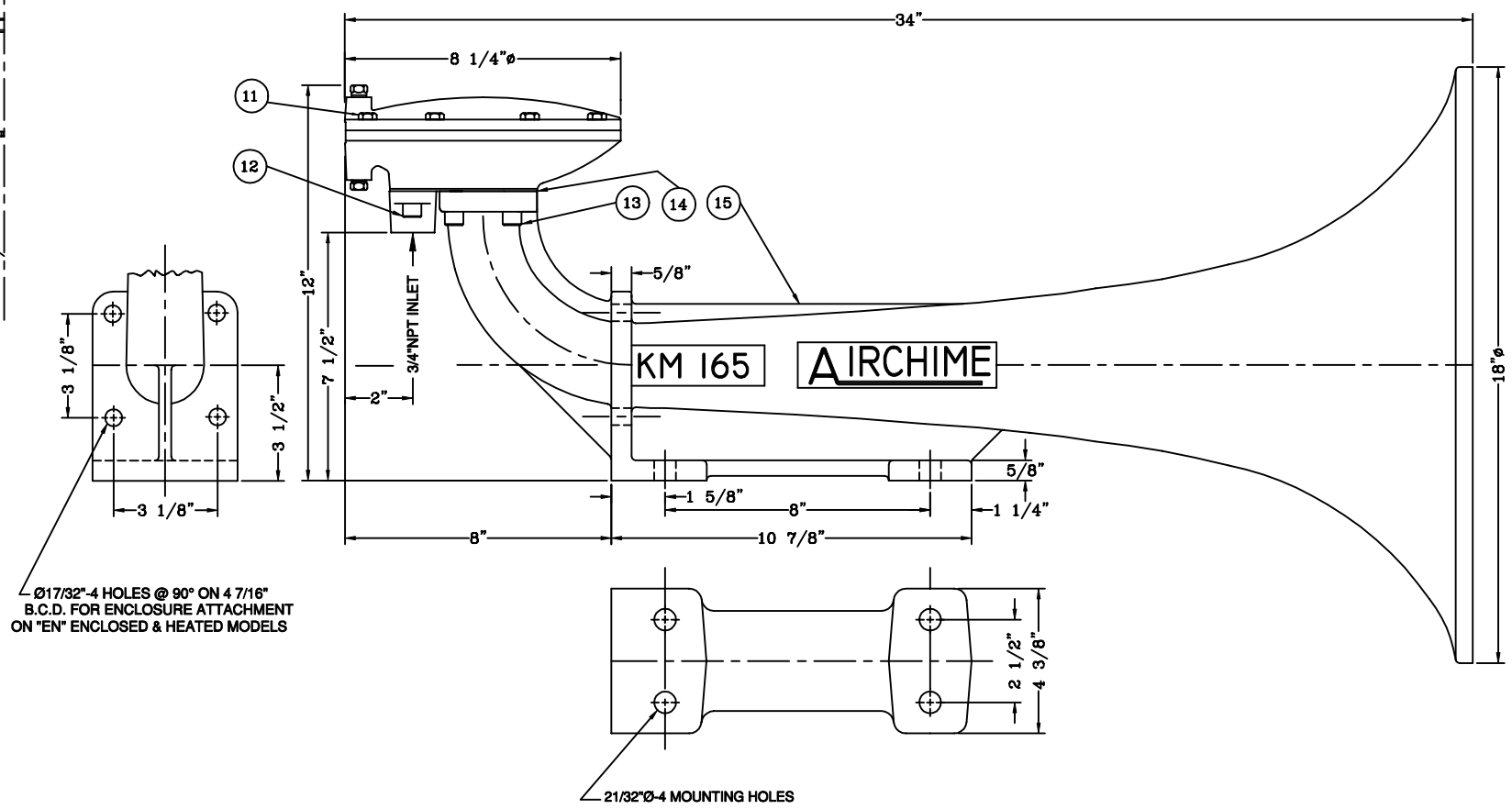
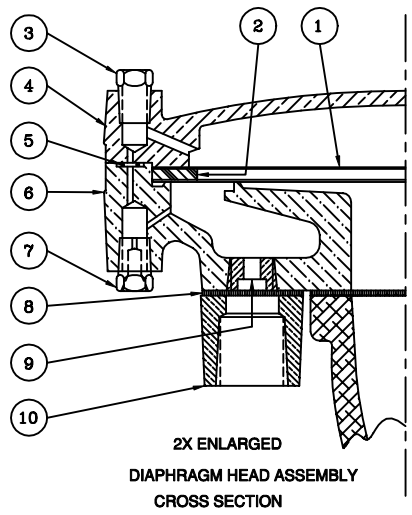

Ø17/32"-4 HOLES @ 90° ON 4 7/16"
B.C.D. FOR ENCLOSURE ATTACHMENT
ON "EN" ENCLOSED & HEATED MODELS

RECOMMENDED SPARE PARTS

REF	PART	DESCRIPTION	MATERIAL	SPECIFICATION	QTY
1	32111	DIAPHRAGM DISC	STAINLESS STEEL	UNS S30100	2
2	32112	CUSHION RING	SILICONE RUBBER	ASTM D2000 FC-FE	1
3	10842	PLUG	STAINLESS STEEL	UNS S31600	1
4	32090	DIAPHRAGM CAP	CAST ALUMINUM	UNS A05352	1
5	32164	O RING	BUNA N	MIL STD 417 SB	1
6	32092	DIAPHRAGM HEAD	CAST ALUMINUM	UNS A05352	1
7	10843	LEAK PLUG	STAINLESS STEEL	UNS S31600	1
8	32108	INLET GASKET	POLY FIBRE, TN-9000	ASTM F104	1
9	10839	RESTRICTOR	STAINLESS STEEL	UNS S30400	1
10	32095	INLET FLANGE	CAST ALUMINUM	UNS A05352	1
11	13105	HEX HEAD CAP SCREW	STAINLESS STEEL	ASTM F593C	8
12	32115	SOCKET HEAD CAP SCREW	STAINLESS STEEL	ASTM F837	2
13	32114	SOCKET HEAD CAP SCREW	STAINLESS STEEL	ASTM F837	4
14	32107	HEAD GASKET	POLY FIBRE, TN-9000	ASTM F104	1
15	32123	BELL No. 165	CAST ALUMINUM	UNS A13562 T6	1

NOTE:
EXCEPT FOR HOLE CENTRES, ALL DIMENSIONS ARE FOR REFERENCE PURPOSE ONLY.
FINISH: PRIMED AND COATED WITH GREY MARINE ENAMEL PAINT

<p>CONFIDENTIAL</p> <p>INFORMATION CONTAINED HEREIN IS CONFIDENTIAL. IT IS THE PROPERTY OF AIRCHIME MFG. CO. LTD., IT IS TO BE USED SOLELY FOR THE PURPOSE PROVIDED, AND IT IS NOT TO BE DISCLOSED TO OTHERS WITHOUT THE PRIOR WRITTEN CONSENT OF AIRCHIME MANUFACTURING COMPANY LIMITED.</p> <p>© CopyRight Airchime Mfg. Co. Ltd.</p>	CONTRACT NUMBER		 <p>AIRCHIME MANUFACTURING CO. LTD. LANGLEY, B.C. CANADA V4W 3S8</p>	
	CUSTOMER:			
	DRAWN BY: L.H.F.	DATE (YR-MO-DA) 97-09-24	<p>MODEL KM-165 AIR HORN, 165 Hz ASSEMBLY AND DIMENSIONS</p>	
	CHECKER: B.W.C.	APPROVED: B.W.C.		
DRAWING STATUS: UNCONTROLLED & ACTIVE		SIZE A	<p>DRAWING NUMBER: 32232</p>	
DRAWING TYPE: ASSEMBLY		SCALE: NONE	<p>SHEET: 1 OF 1</p>	